

Model: LWS Lead and Wire Seals

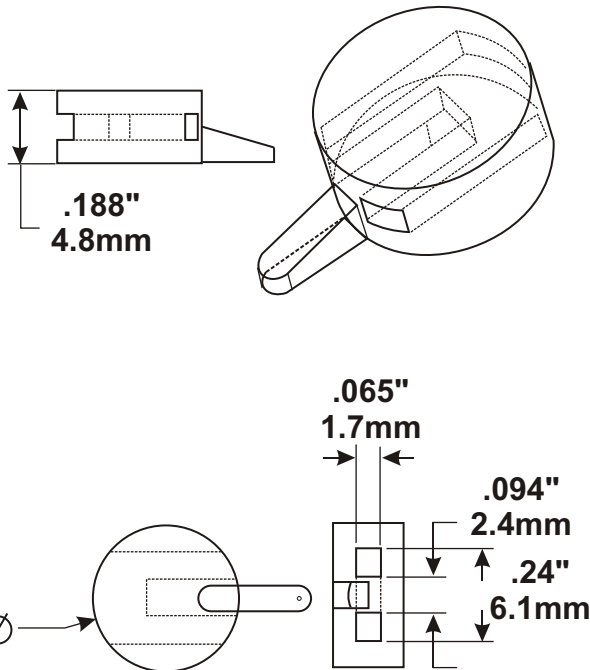

DESCRIPTION:

AC&M's LWS Lead and Wire Seals, serves many types of uses. Any length and style of wire already attached to lead seals. For all applications, use with our 5" Bulldog Seal Press. Available with 3/8", 7/16", 1/2", and 9/16" (9.5, 11.1, 12.7, 14.3 mm) diam. leads.

PACKAGING:

- 250 Seals to a poly bag.

Cartons containing 1,000 seals measure: 10" x 13" x 17" and weigh 8 Lbs. 25.4cm x 33cm x 43cm and weigh 3.6 kg.

USE:

Applies with a 5" Bulldog Seal Press. Cannot be opened unless the seal is destroyed.

Available Diameters:

- Ø 3/8" - 9.5mm
- Ø 7/16" - 11.1mm
- Ø 1/2" - 12.7mm
- Ø 9/16" - 14.3mm



**American Casting
& Manufacturing Corporation**

Toll-Free (800)342-0333

Tel: (516) 349-7010 • Fax (516) 349-8389

www.SEALS.com

email: info@SEALS.com

51 Commercial St · Plainview, NY 11803 USA